

Specification

- Clean Water only.
- Multistage.
- c/w Float switch (adjustable)
- 230v 50Hz
- 1100 Watts
- 10.8 Kgs
- To 90 Lites/min
- 45 Meters Max Head
- 1" BSPf Outlet c/w Non Return Valve and Stepped hose tail outlet.
- H 400mm x W 150mm x D150mm
- Complete with 15m Power cable & plug..
- Suitable for traditional well, water deposits & collection tanks and small scale irrigation.



Applications

- ~ Muti Impellers for clear water.
- ~ Corosion proof Construction.
- ~ Moror Overload Protection.
- ~ SS Strainer Intake.
- ~ 15m Supply Cable with plug.
- ~ Non return valve on Outlet.
- ~ Multi 4 step Hose adaptor.

Ideal for:-
 Rain water Systems.
 Operating Sprinklers.
 Pumping water from tanks



HYDRAULIC DATA

TECHNICAL DATA

Model	HP	Watts	Volts	Frequency	Amps	FloatSwitch	MaxFlow	Max Head	Impellers	Max PSI
ECODIVER 1200	1	1100	240	50 Hz	9.8	No		157 ft	4	64
ECODIVER 1200-A						Yes				

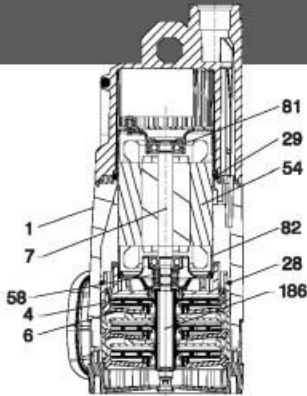

TECHNICAL DATA



TECHNICAL DATA

CONSTRUCTION

No.	Description	Material
1	Pump Body	PP OMO 30% FVAC
4	Impeller	PPO/PPE 20% FV
6	Diffuser	PPO/PPE 20% FV
7	Rotor Shaft	INOX AISI 416
28	O Ring	NBR 70
29	O Ring	NBR 70
54	Motor Casing	fe PO1 0.65mm
58	Ceramic Bush	INOX AISI 416
81	UpperBearingSupport	Cast Aluminium
82	LowerBearingSupport	Cast Aluminium
186	Pump Shaft	Hexagonal AISI 303

TECHNICAL DATA

FEATURES & BENEFITS

- Plug & Play
- Large range to cover various requirements
- Provides Excellent flows "In a compact design"
- Efficient motors
- 115v 60Hz
- CSA and UL approved
- Dry Run protection (with Float Switch)
- Built in thermic overload

DIMENSIONS

Model	H	H1	A	ØB	Weight
ECODIVER 1200	15.8"	13.5"	5.9"	1"	19.4 lbs
ECODIVER 1200-A	15.8"	13.5"	5.9"	1"	19.8 lbs

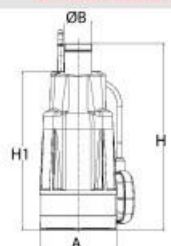

2020 Price £265.00 nett

sales@everyvalve.com